



SILO V2™ 型筒料仓收尘机宣传册

电话: 022-27336597
传真: 022-27272895

Internet: www.fluid-controls.cn/wam/



SILO V2™ Silo Venting Filters

Vibrating Cleaning System

Silo Filling



Dust is separated from the dirty air flow while clean air is evacuated from the filter

Filter Cleaning



Dust drops down into the silo due to vibrating filter elements

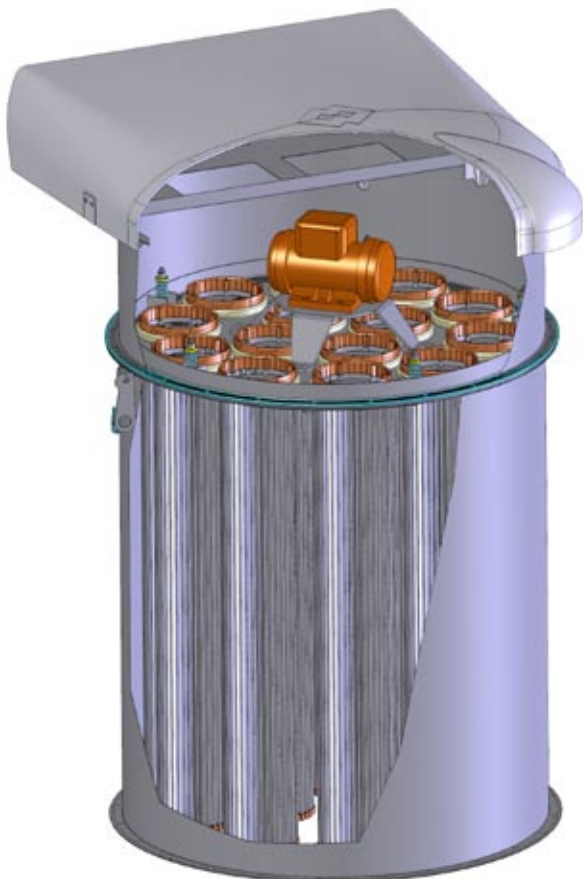

User-Friendly Maintenance

- Maintenance height = 1,280mm (4 ft)
- No tools for cartridge maintenance needed

SECURE and CONFORM TO STANDARDS

- Dust emission < 20 mg/Nm³
- Noise level < 75 dB(A)
- Safe connection flange
- High filtration efficiency

Feature - 特性

Function - 功能

Benefits - 优点

Standard Stainless Steel Body
标准不锈钢外壳

Resistance to Corrosion
防恶劣气候表面处理

Reduced Maintenance Costs Due to Increased Durability
增强耐用性减少维护成本

High Quality Filter Media
高效滤芯

High Filtration Efficiency
高滤尘效率

Lower Dust Emission
低粉尘外泄

Push-Fit Filter Elements
推入式安装的滤芯

No tools for cartridge maintenance needed (no loss of hardware)
快捷安全的维护（无硬件损失）

Lower Maintenance Costs
较低的维护成本

Maintenance Height = 1,280mm (4 ft)
维护高度=1280mm（4英尺）

Easy Maintenance
维护方便

Increased Work Safety - Reduced Maintenance Costs
增加工作安全性-降低维护成本



PATENTED

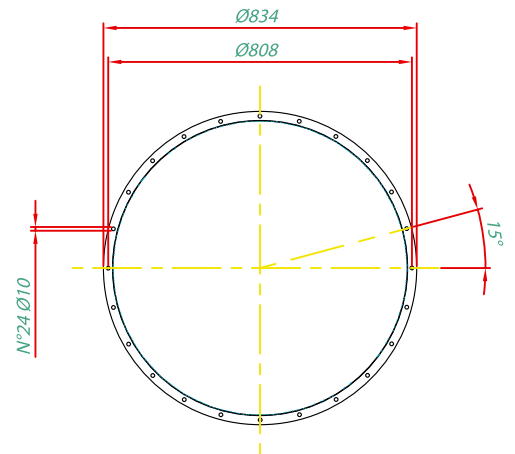
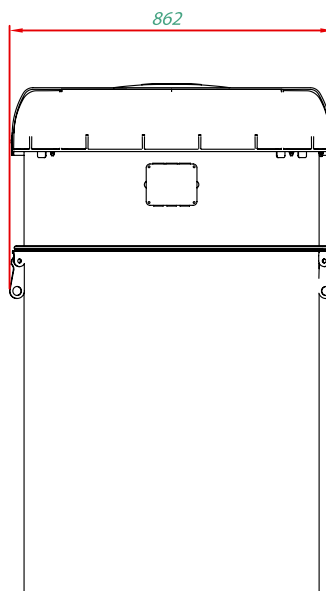
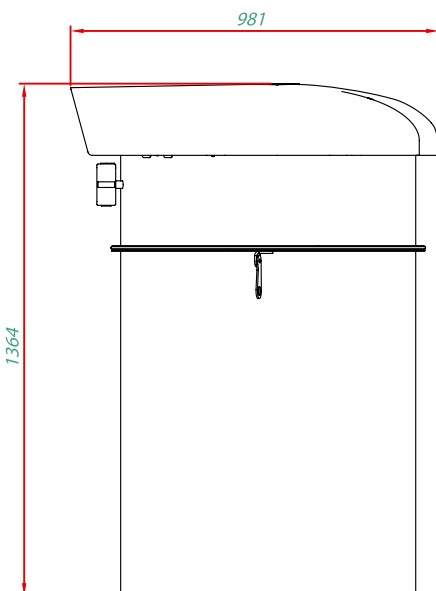



For more information please visit our website:

